

# MotorGuide® REPAIR PARTS

**Model:**  
**QS370V**

**SPECIFICATIONS:**

Year of Intro 1996  
 Thrust 41LBS  
 Volts 12VDC  
 Amp Draw 0 to 48 amps  
 Mount 03 Transom  
 Speeds Variable

**QUICK REFERENCE PARTS GUIDE:**

Rotary Switch KT150-02  
 ON/OFF Switch TT3149-03  
 DA Board JF157-03  
 MOSFET JF096-07  
 Motor Seal Kit 6220  
 Slide Pot TT168-06

**PARTS ORDERING & TECH ASSISTANCE**

MotorGuide Consumer Relations  
 Phone 918-831-6989  
 Fax 800-982-8093

**Send Returned Goods to:**  
 MotorGuide  
 605 Hwy 12 West  
 Starkville, MS 39760

*Returned Goods must be accompanied with a Returned Goods Authorization. Contact MotorGuide Consumer Relations to obtain RGA.*

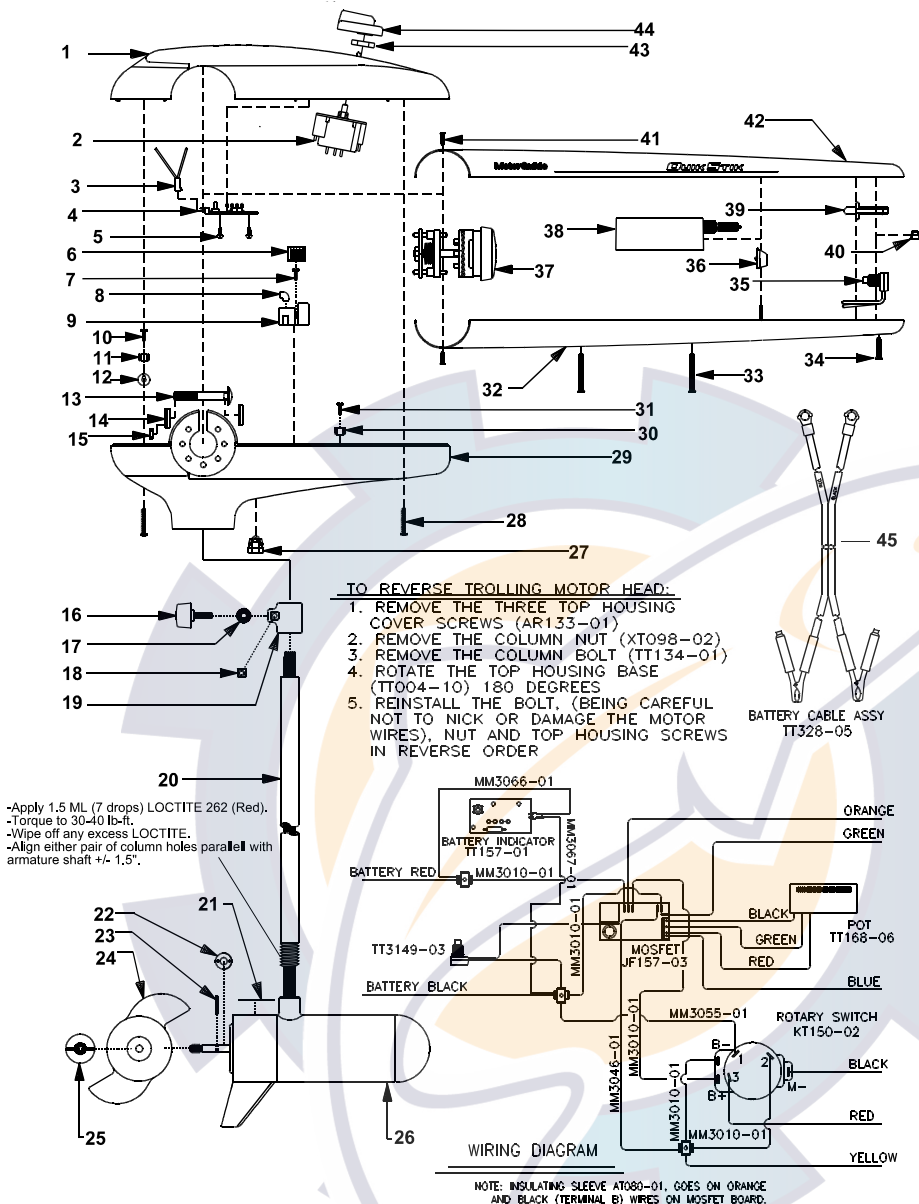

KEY#	PART#	DESCRIPTION
1	TT053-10	COVER 5 SPD QS GENERIC
2	KT150-02	ROTARY SWITCH
3	WF329-01	CONNECTOR/JUMPER ASY
4	TT157-01	BATTERY LEVEL INDICATOR
5	AF141-01	SELF TAPPING SCREW
6	AP029-01	AMP CONNECTOR
7	AF141-01	SELF TAPPING SCREW
8	AT080-01	INSULATING SLEEVE
9	JF157-03	12V DURA AMP BOARD
10	GR133-01	310 X 1/2 SCREW
11	FT160-03	TERMINAL (4 PRONG)
12	TT098-03	ON SERT PAL NUT
13	TT134-01	BOLT
14	TT171-04	CURVED WASHER
15	XT098-02	NYLON LOCK NUT
16	AR082-02	BAR KNOB DEPTH ADJUST
17	AR171-01	COLUMN CLAMP WASHER
18	FR098-01	COLUMN SUPPORT NUT
19	AR051-01	DEPTH ADJUST COLLAR
20	TT049-04	COLUMN 30"
	FR049-15	COLUMN 42"
21	ET060-04	LOWER UNIT DECAL
22	AR175-01	MONOFILAMENT WASHER
23	BR102-01	PROP PIN
24	AF124-10	3 BLADE PROP
25	AR099-01	PROP NUT

KEY#	PART#	DESCRIPTION
26	CF397-05	LOWER UNIT
27	GR019-01	BATTERY CABLE BUSHING
28	AR133-01	8 X 1 3/8 SCREW
29	TT004-10	T/H BASE GENERIC
30	FT160-03	TERMINAL 4 PRONG
31	GR133-01	310 X 1/2 SCREW
32	TT072-05	LOWER HANDLE QS BLACK
33	TT133-03	#6 X 1" SCREW
34	TT133-02	#6 X .75 SCREW
35	TT3149-03	ON/OFF SWITCH ASY
36	TT3001-03	ACTUATOR ASY
37	TT372-04	HANDLE CLUTCH ASY
38	TT168-06	POTENTIOMETER
39	TT001-04	ACTUATOR ON/OFF
40	TT177-02	SWITCH BOOT
41	TT133-01	#6 X .437 SCREW
42	TT072-12	UPPER HANDLE
43	AT098-01	PAL NUT
44	TT082-06	ROTARY KNOB
45	TT328-05	BATTERY CABLE ASY

**PARTS NOT ILLUSTRATED**

TT056-07 DECAL  
 MM5604 OWNERS MANUAL

LOWER UNIT BREAKDOWN

Model:  
**QS370V**

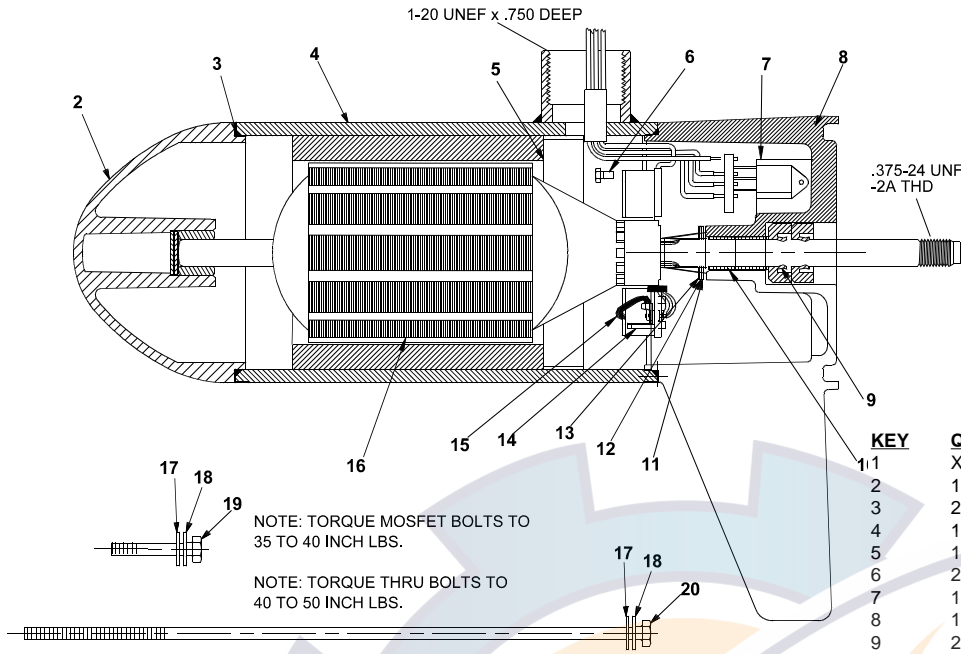

NOTE: TORQUE MOSFET BOLTS TO 35 TO 40 INCH LBS.

NOTE: TORQUE THRU BOLTS TO 40 TO 50 INCH LBS.

DIRECTION OF ROTATION IS COUNTER CLOCKWISE WHEN VIEWED FROM PROPELLER END WITH RED POSITIVE & BLACK NEGATIVE.

KEY	QTY	DESCRIPTION	PART NO.
1	X	MOTOR	CF397-05
2	1	NOSE CAP	JF3212-01
3	2	O RING SEAL	MR217-01
4	1	HOUSING ASY	JF3210-01
5	1	RETAINER	JF233-01
6	2	BRUSH CARD SCREW	MR228-01
7	1	DURA AMP MODULE	JF096-07
8	1	COMM CAP	JF3205-04
9	2	SHAFT SEAL	MR223-01
10	1	BEARING	MR206-01
11	1	NYLATRON WASHER	MR226-01
12	1	WASHER	MR227-01
13	1	E RING	MR219-02
14	2	BRUSH SPRINGS	MR214-02
15	1	BRUSH ASY LESS SPRING	JF3201-03
16	1	ARMATURE 3.5"	CF3207-01
17	4	STATIC SEAL	MR222-01
18	4	THRU BOLT WASHER	MR216-01
19	2	DURA AMP SCREW	MR229-04
20	2	THRU BOLT	MR218-02

WIRING

